

# EasyGrade Mini B

Accurate Finish with Easy to Operate Controls



## Standard Features

- Box-Style Blade
- Front and Rear Fixed Curved Cutting Edge
- Twin Castor Walking Beam
- Proportional Control Valve
- Solid Fill Tyres
- Universal Hitch
- Fully Greaseable Linkage
- Large Blade View Mirrors
- Standard Replacement Components

## Options

- Machine Control Packages
- Dual Axis Lift

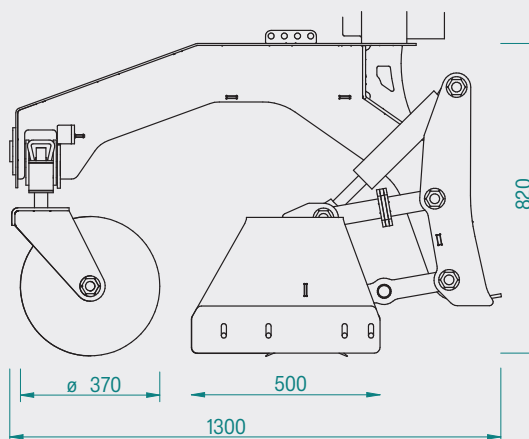

	EGM12B	EGM18B
Horsepower Range	20 - 30	40 - 55
Machine Width (mm)	1250	1850
Cutting Width (mm)	1200	1800
Length (mm)	1300	
Approx. Weight (kg)	260	300



CELEBRATING **40 Years**



# AUSTRALIAN MADE EARTHMOVING EQUIPMENT



## Box Blade

- **Front and Rear Curved Blade** - Improved Surface Finish w. Push-Pull Design
- **Fixed Wings** - 8mm Wing w. Hardox® Adjustable Wear Plates
- **Adjustable Linkage** - Ensures Both Blades Cut at the Same Height Integrated
- **Integrated Mast Brackets** - Easily Remove Masts for Transport



## Walking Beam

- **Twin Castors** - Improves Machine Stability and Finish Quality
- **Solid Fill Tyres** - Greater Load Carrying Capacity w. No Punctures
- **Bump Stops** - Rubber Dampeners to Cushion Movement of Walking Beam
- **Standard Bearings and Pins** - Easy to Maintain and Replace



## Dual Axis Lift

- **Dual Lift** - Allows for Independent Left and Right Blade Control
- **Retrofittable** - Upgradable When Required
- **Additional Machine Capability** - Get on Grade Faster!
- **Multiple Control Configurations** - Laser and GPS Compatible



## Control Valve

- **Proportional Solenoids** - Provides Fast and Accurate Blade Movement
- **Modular** - Easily Expanded to Accommodate Dual Axis Lift
- **Hydraulic Flow Protection** - Check Valve to Eliminate Accidental Damage
- **Genuine Walvoil™ Valve** - Spare Parts Available Nationwide

